

Every Topic on the AQA  
2022 Advanced Information  
Practice Booklet  
Paper 2 (Calculator)

Higher Tier



**GCSE**  
Maths Tutor



How it all Works!

Work through the practice booklet,  
scan the code, watch the live  
tutorial and check your answers!

**Try it out!**

Disclaimer: There is no guarantee that any specific topic will be examined this way in the summer and you cannot rely on this as your only source of revision. Please visit the YouTube channel for in depth lessons on each of the topics within this document along with any recommended revision that has been instructed by your education provider.

[www.thegcsemathstutor.co.uk](http://www.thegcsemathstutor.co.uk)

**Answer ALL questions.**

**Write your answers in the spaces provided.**

**You must write down all the stages of your working.**

1. Work out  $1\frac{3}{4} \times 1\frac{1}{3}$

Give your answer as a mixed number in its simplest form.

.....  
(3 marks)

2. Express 180 as a product of prime factors.

.....  
(3 marks)

3. Find the value of the reciprocal of 1.6

Give your answer as a decimal.

.....  
(2 marks)

4. a) 37.2 has been rounded to 1 decimal place.

Write down the error interval.

.....  $\leq x <$  .....  
(2 marks)

b) 340 has been rounded to 2 significant figures.

Write down the error interval.

.....  $\leq x <$  .....  
(2 marks)

5.  $R = \frac{V}{I}$

$V = 43.52$  correct to 2 decimal places.

$I = 5.437$  correct to 3 decimal places.

Work out the upper bound for  $R$ .

Give your answer to 3 decimal places.

.....  
(3 marks)

6. A train takes 3 hours to complete a journey correct to the nearest 5 minutes.  
The length of the journey is 260 miles correct to the nearest 10 miles.  
By considering bounds, work out the average speed of the train.  
You must give a reason for your answer.

.....  
(4 marks)

7. a) Evaluate  $3^{-2}$

.....  
(2 marks)

- b) Write down the value of  $25^{-\frac{1}{2}}$

.....  
(2 marks)

8. Solve  $\frac{4x+1}{3} = 2x - 2$

.....  
(3 marks)

9. a) Solve the inequality  $3x - 5 < 7$

.....  
(2 marks)

b) Show your answer to part (a) on the number line.

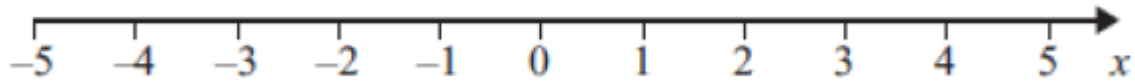

(2 marks)

10. a) Solve the inequality  $-5 \leq 2x + 3 < 7$

.....  
(3 marks)

b) Show your answer to part (a) on the number line.

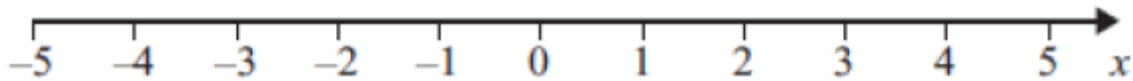

(2 marks)

10. The point (3,4) lies on the circumference of a circle centre (0,0)

Write down the equation of the circle

.....  
(3 marks)

11. Write down the equation of the line that passes through the points  $(-3,4)$  and  $(5,8)$

.....  
(3 marks)

---

12. A line passes through the points  $(1,5)$  and  $(5,7)$ .

Find the equation of a perpendicular line that passes through the point  $(-1,7)$ .

.....  
(3 marks)

13. a) Find the equation of the tangent to the circle with equation  $x^2 + y^2 = 17$  at the point  $(1, p)$  where  $p$  is positive.

.....  
(4 marks)

- b) Hence, find the coordinates where the tangent intersects the  $x$ -axis.

.....  
(2 marks)

14. a) Expand and simplify  $4(x - 3) - 2(1 - x)$

.....  
(2 marks)

b) Expand and simplify  $(2x - 1)(2x - 5)$

.....  
(2 marks)

---

15. a) Factorise  $x^2 - 2x - 15$

.....  
(1 mark)

b) Solve  $2x^2 - x - 1 = 0$

.....  
(2 marks)

---

16. Solve  $3x^2 + 2x - 13 = 0$

Give your answers correct to 3 significant figures.

.....  
(3 marks)



17. a) Write  $x^2 - 8x - 4$  in the form  $(x - a)^2 - b$  where  $a$  and  $b$  are integers.

.....  
(3 marks)

b) Hence, find the coordinates of the turning point for the graph  $y = x^2 - 8x - 4$

.....  
(1 mark)

---

18. a) Given that  $f(x) = 3x + 4$

Work out an expression for  $f^{-1}(x)$

.....  
(2 marks)

b) Given that  $f(x) = 2(x + 2)$

Work out the value  $f^{-1}(10)$

.....  
(3 marks)

19. The triangular numbers are 1, 3, 6, 10, ...

The  $n$ th term of this sequence is  $\frac{1}{2}n(n + 1)$

Find the 200<sup>th</sup> triangular number.

.....  
(2 marks)

20. £360 is shared between Abby, Ben, Chloe and Denesh.

The ratio of the amount Abby gets to the amount Ben gets is 2: 7

Chloe and Denesh each get 1.5 times the amount Abby gets.

Work out the amount of money that Ben gets.

.....  
(4 marks)

21. The points A, B, C and D lie in order on a straight line.

$AB : BD = 2 : 5$  and  $AC : CD = 4 : 7$

Find  $AB : BC : CD$

.....  
(3 marks)

22. At the end of 2015  
the value of Alice's house was £240,000  
the value of Karl's house was £170,000

At the end of 2018  
the value of Alice's house had decreased by 20%  
the value of Karl's house had increased by 30%

At the end of 2018, whose house had the greater value?  
You must show how you get your answer.

.....  
(4 marks)

23. Tame Valley is a company that makes yoghurt.  
A machine fills trays of 20 pots with yoghurt.  
In one hour, the machine fills a total of 15,000 pots.  
Work out how many seconds the machine takes to fill each tray of 20 pots.

.....  
(3 marks)

24. It takes 8 machines 9 days to complete a job.  
On the first day 3 machines are used,  
on the second day 6 machines are used,  
for the remaining days, 7 machines are used.  
How many day does it take to complete the job?

.....  
(3 marks)

25.  $pressure = \frac{force}{area}$

A force of 70 newtons acts on an area of  $20cm^2$

The force is increased by 10 newtons

The area is increased by  $10cm^2$

Does the pressure decrease by less than 20%?

You must show how you get your answer.

.....  
(3 marks)

26. The plan, front elevation and side elevation of a solid prism are drawn on a centimetre grid.

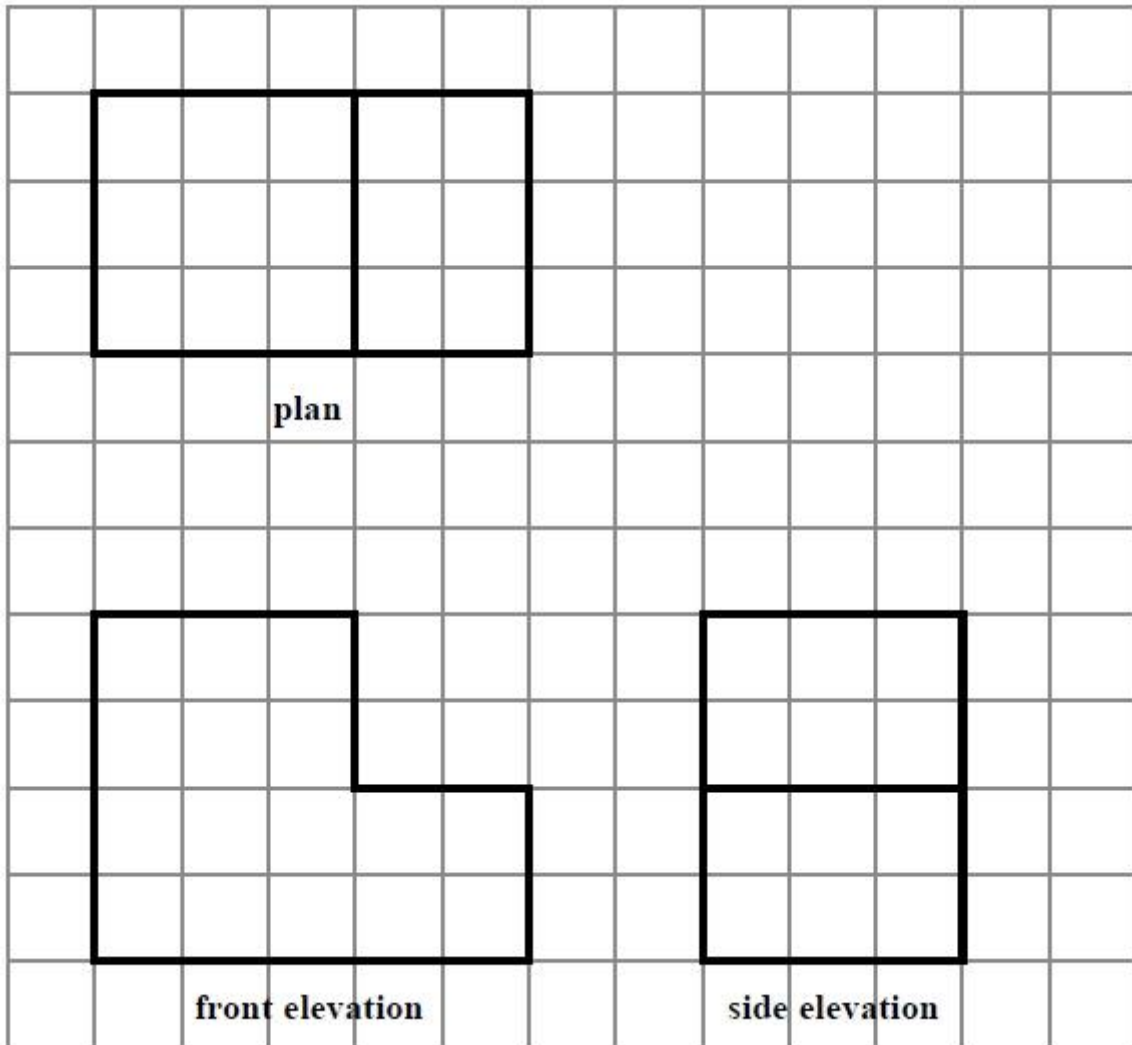

In the space below, draw a sketch of the solid prism.  
Write the dimensions of the prism on your sketch.

(2 marks)

27.

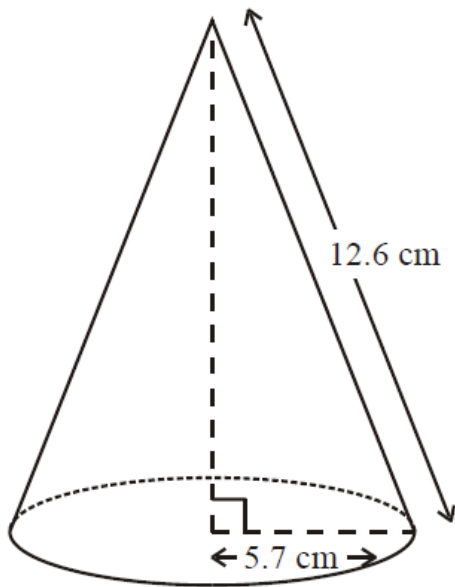
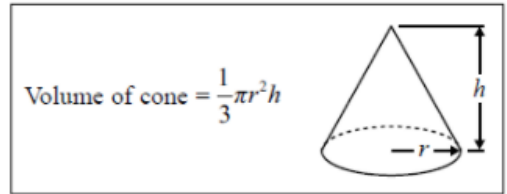

Diagram **NOT** accurately drawn



The radius of the base of a cone is 5.7 cm.

Its slant height is 12.6 cm.

Calculate the volume of the cone.

Give your answer correct to 2 decimal places.

.....  
(3 marks)

28. The diagram shows a solid hemisphere of radius 8cm.

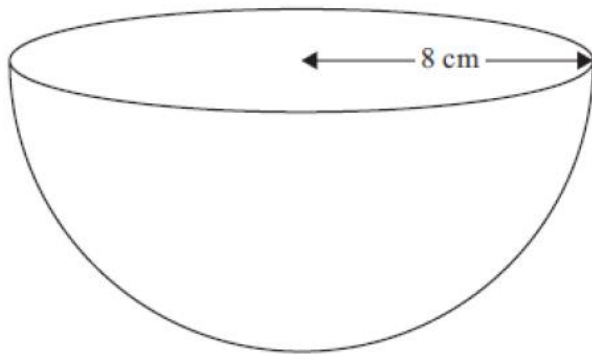
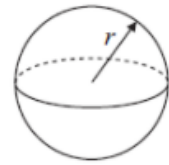

Diagram NOT  
accurately drawn

Volume of sphere =  $\frac{4}{3}\pi r^3$   
Surface area of sphere =  $4\pi r^2$



Work out the surface area of the hemisphere.

Give your answer to 2 decimal places.

.....  
(4 marks)

29.  $ABCDE$  is a pentagon.

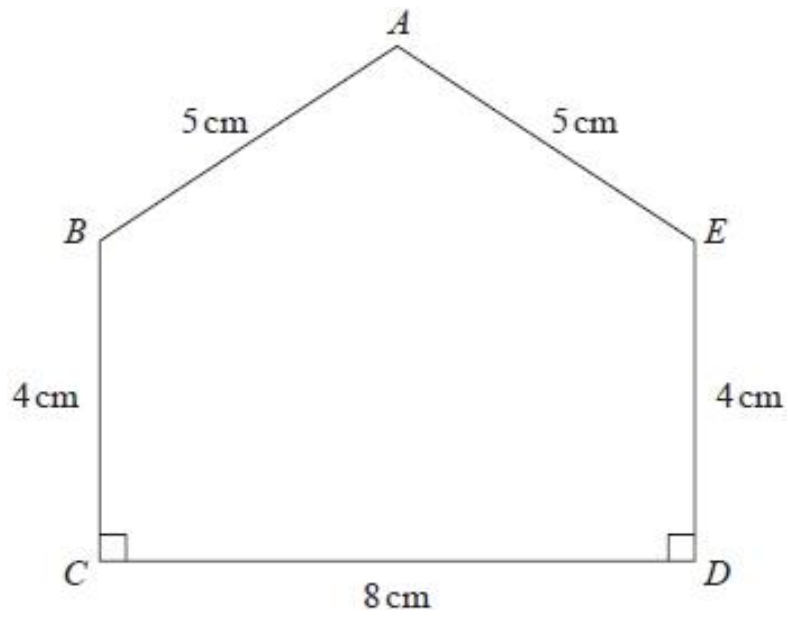

Work out the area of  $ABCDE$

.....  
(5 marks)



30. Two cylinders are mathematically similar.

The height of cylinder A is 3cm.

The height of cylinder B is 9cm.

The volume of cylinder B is  $540\text{cm}^2$ .

Work out the volume of cylinder A.

.....  
(2 marks)

31.

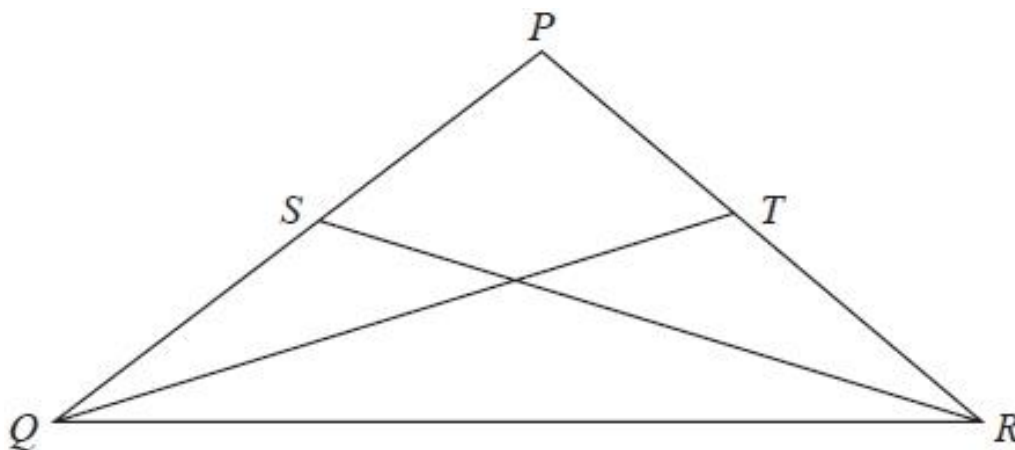

$PQ = PR$ .

$S$  is the midpoint of  $PQ$ .

$T$  is the midpoint of  $PR$ .

Prove triangle  $QTR$  is congruent to triangle  $RSQ$ .

(3 marks)

32. The table gives information about the languages studied by a group of year 11 students.

<b>French</b>	<b>German</b>	<b>Spanish</b>
30	37	53

Draw an accurate pie chart for this information.

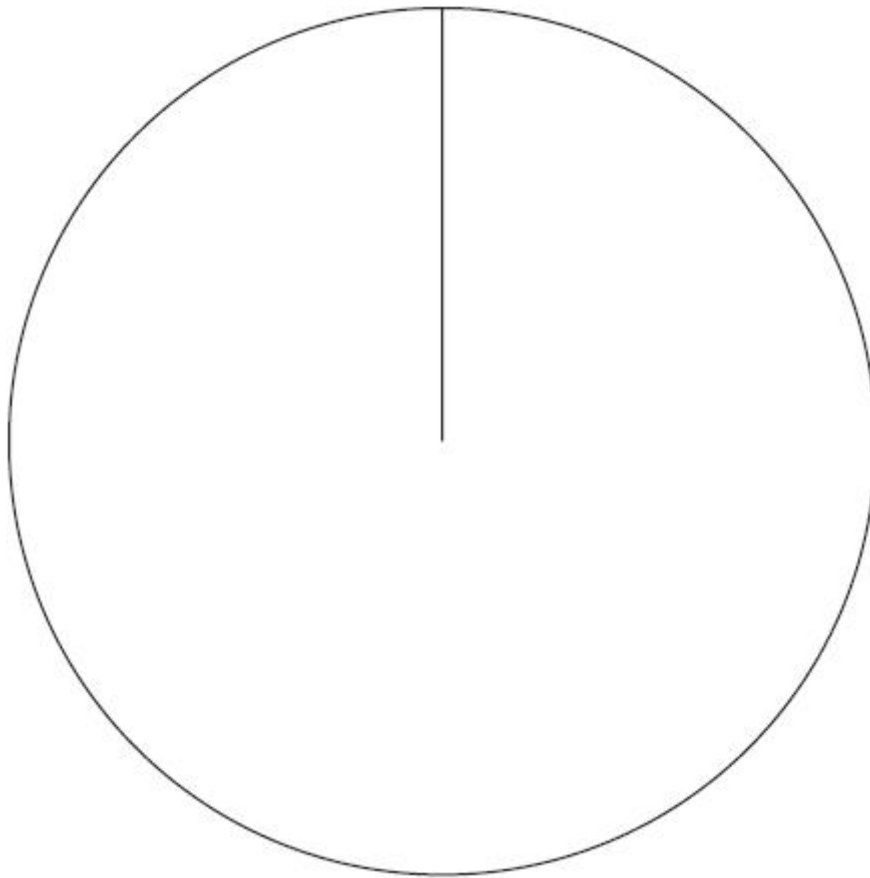

(3 marks)

33. 20 men, 10 women and 10 children are in a competition.

The mean score for the women is 15.6

The mean score for the children is 9.2

The mean score for all 40 people is 11.2

Work out the mean score for the men.

.....  
(3 marks)

34. Rosie had 10 boxes of drawing pins.

She counted the number of drawing pins in each box.

The table gives information about her results.

Number of drawing pins	Frequency
29	2
30	5
31	2
32	1

Work out the mean number of drawing pins in a box.

.....  
(3 marks)

34. Hannah is planning a day trip for 195 students.  
She asks a sample of 30 students where they want to go.  
Each student chooses one place.

The table shows information about her results.

Place	Number of Students
Theme Park	10
Theatre	5
Sports Centre	8
Seaside	7

a) Work out how many of the 195 students you think will want to go to the theme park.

.....  
(2 marks)

b) State any assumption you made **and** explain how this may affect your answer.

.....  
.....  
.....

(1 mark)

35. An electronic game can show red or blue or green or yellow.

The table shows the probabilities that the colour shown will be red or will be green or will be yellow.

Colour	Red	Blue	Green	Yellow
Probability	0.15		0.41	0.24

Arthur plays the game.

a) Work out the probability that the colour will be blue.

.....  
(2 marks)

Janice is going to play the game 50 times.

b) Work out an estimate for the number of times the colour shown will be yellow.

.....  
(2 marks)

---

**End of Paper**